

# Full Height Turnstile

## DSP60 Tiffany Series

Interior Application

The DSP60 is a three-vane turnstile with an anodized aluminum finish and is shipped pre-configured to your security needs. It is constructed with a heavy duty overhead canopy, extruded aluminum columns, MR10 Lexan— polycarbonate cage panels, and ¾" MP750 Lexguard® arm panels for a more modern and open look.



DSP60 Series



### FEATURES & BENEFITS

- Your choice of clear or dark bronze
- Automatic indent Feather-Touch action that includes shock suppressor technology and a non-entrapment design
- Ideal for corporate headquarters, or anywhere that high security functionality and top-notch appearance are desired
- Scratch resistant Lexguard® arms
- Auto indexing (self centering) with adjustable hydraulic shock suppression

**DSI**<sup>®</sup>  
DESIGNED SECURITY, INC.  
*Building Security*

1402 Hawthorne St.  
Bastrop, Texas 78602  
Voice: 1-800-272-3555  
Fax: 1-512-321-9181  
E-mail: [dsi@dsigo.com](mailto:dsi@dsigo.com)  
[www.dsigo.com](http://www.dsigo.com)

## Applications:

Featuring scratch resistant Lexguard® arms for a more modern and open look, the DSP60 turnstile provides a high security solution without compromising facility aesthetics.

### Product Features:

#### Dimensions:

Arm Panels: .75" x 21.25" x 31"  
Exterior Height: 91"  
Interior Height: 84"  
Diameter: 72.284"  
Pedestrian Clearance: 30"

#### Finish:

Standard anodized finish choices are clear and bronze. Other colors are available upon request.

#### Construction:

##### Materials:

Various 6061 & 6063 extruded aluminum  
3/16" MR10 Lexan® polycarbonate  
3/4" MP750 Lexguard® laminate  
7 & 11 gauge steel (mainframe/canopy)  
Anodized aluminum sheet, canopy wrap

#### Assembly:

Major lower components assembled with concealed spring pins and solid rods

#### Hardware:

- All exposed hardware stainless steel
- Canopy & outer cage panels secured to concrete with 3/4" threaded rods, epoxied into concrete
- Rotor pivots on a sealed load runner bearing, secured with high strength plastic coupling anchored onto concrete

### Operation:

#### 6500 Series Control Head,

#### Featuring:

- Auto indexing (self centering) with adjustable hydraulic shock suppression
- Hardened tool steel locking bars, cam and roller assemblies
- Permanently lubricated bearings
- Your choice of manual or electronic control, both directions
- Nearly universal integration to any number of access control systems
- Your choice on each electronic direction of locking or unlocking on power failure

#### Options:

- Card reader mounting plates
- Daylight visible indicator lights
- Bi-directional key overrides
- Low voltage canopy lighting
- Additional options available upon request

#### Warranty:

Units are warranted against defects in materials and workmanship for a period of one year from date of invoice.

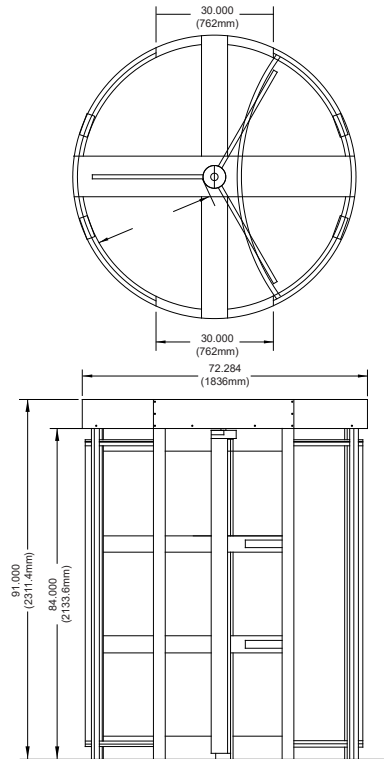

### Electrical Specifications:

Input voltage: 100-240 VAC  
Input current: 1.3 - .55 A  
Frequency: 50/60 Hz

Storage Temperature: -40 to 158°F  
Operating Temperature: -4 to 131°F  
(cold weather package available)

Operating voltage: 24VDC  
Operating current: 1.2 A (typical)